

# Software Defined Radio(SDR)

New Technology or a Geeks Delight?

# SDR Definition

- Any Radio design that uses computer programming to provide decoding of radio signals to convert those signals to a readable/audible format.
- Computer can be inside the box ala Icom 756, Yaesu 2000 or Elecraft K3 or use an external processor such as flex-radio series.

# Technology Evolution

- Analog Radio
- Hybrid Analog/Digital
- Direct conversion analog
- Direct conversion digital

# Analog Radio

- Example Tentec Omni VI
- Classic ham band only design
- Lots of Crystal filter options
- DSP upgrade adds audio filtering

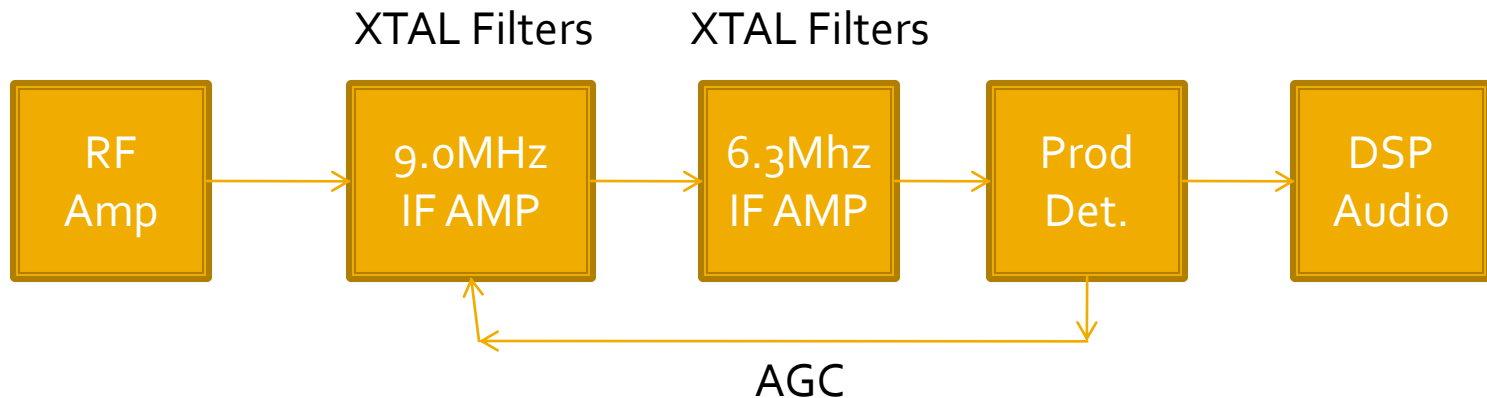

# Hybrid Analog/Digital

- Elecraft K3
- Analog front end good filters
- DSP backend
- Processing is all in the box

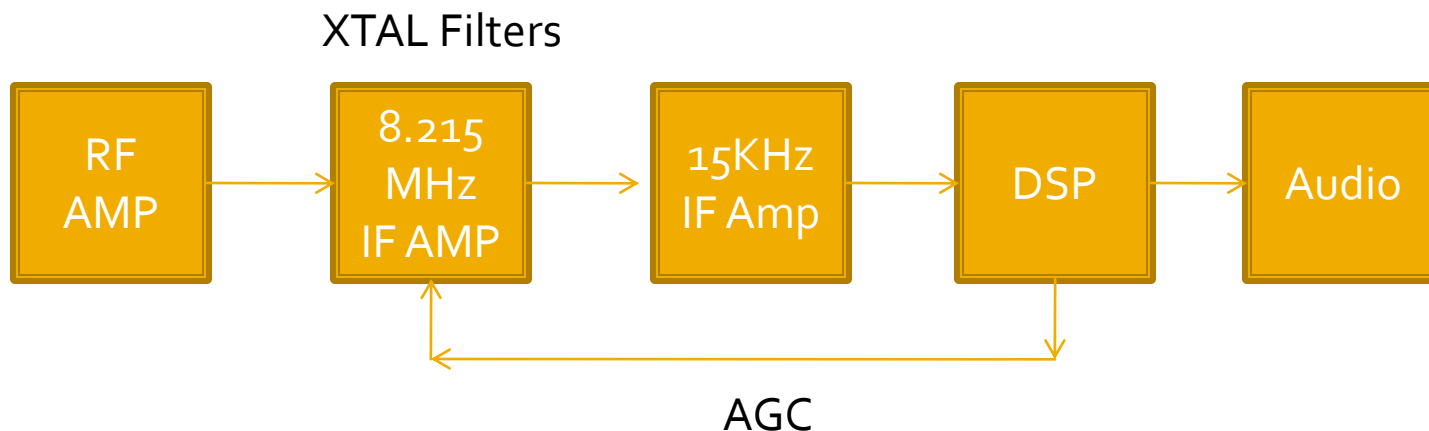

# Direct Conversion - Analog

- Signal is directly converted from RF to Audio
- All gain is in the Audio Stage
- Very popular in QRP radios.

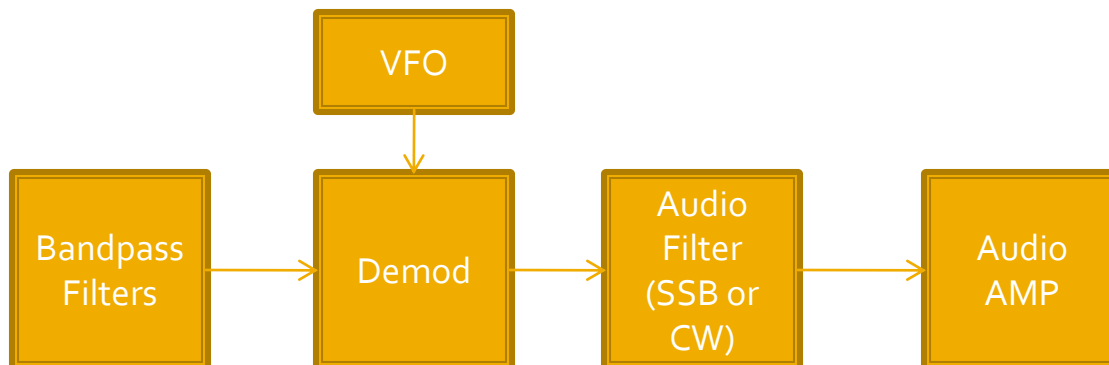

# Analog SDR

- Direct Conversion but---
- All analog processing is done in PC
- Major game changer for Amateur Radio!!
- Extensive software required (free open source)
- \$200 of parts equal \$2,500 Radio!

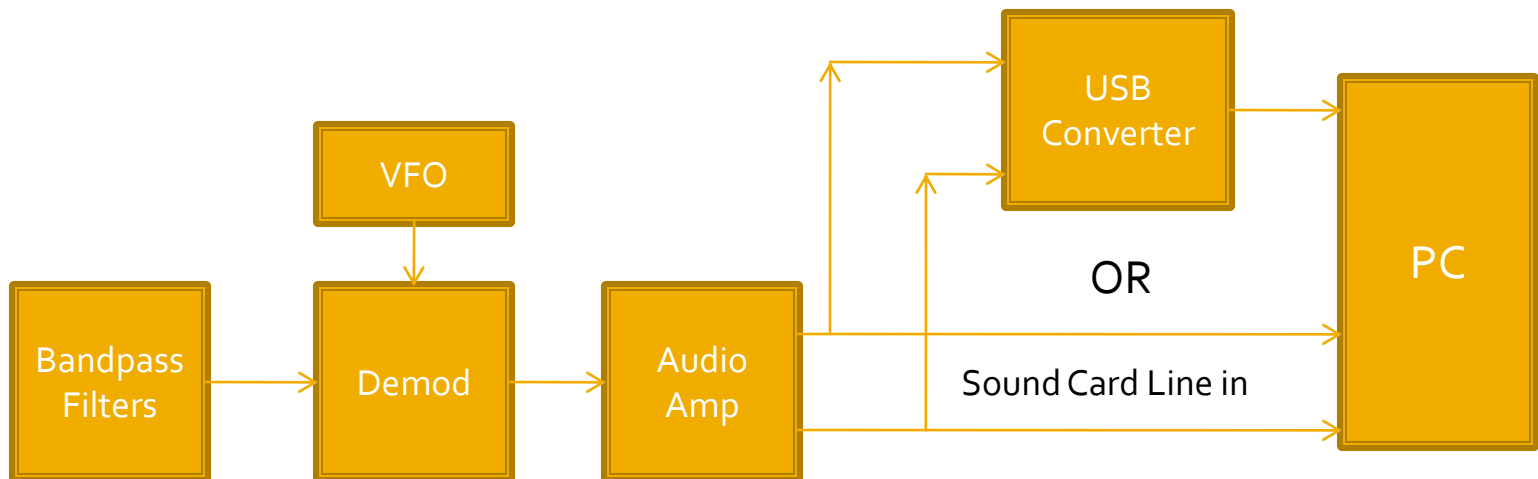

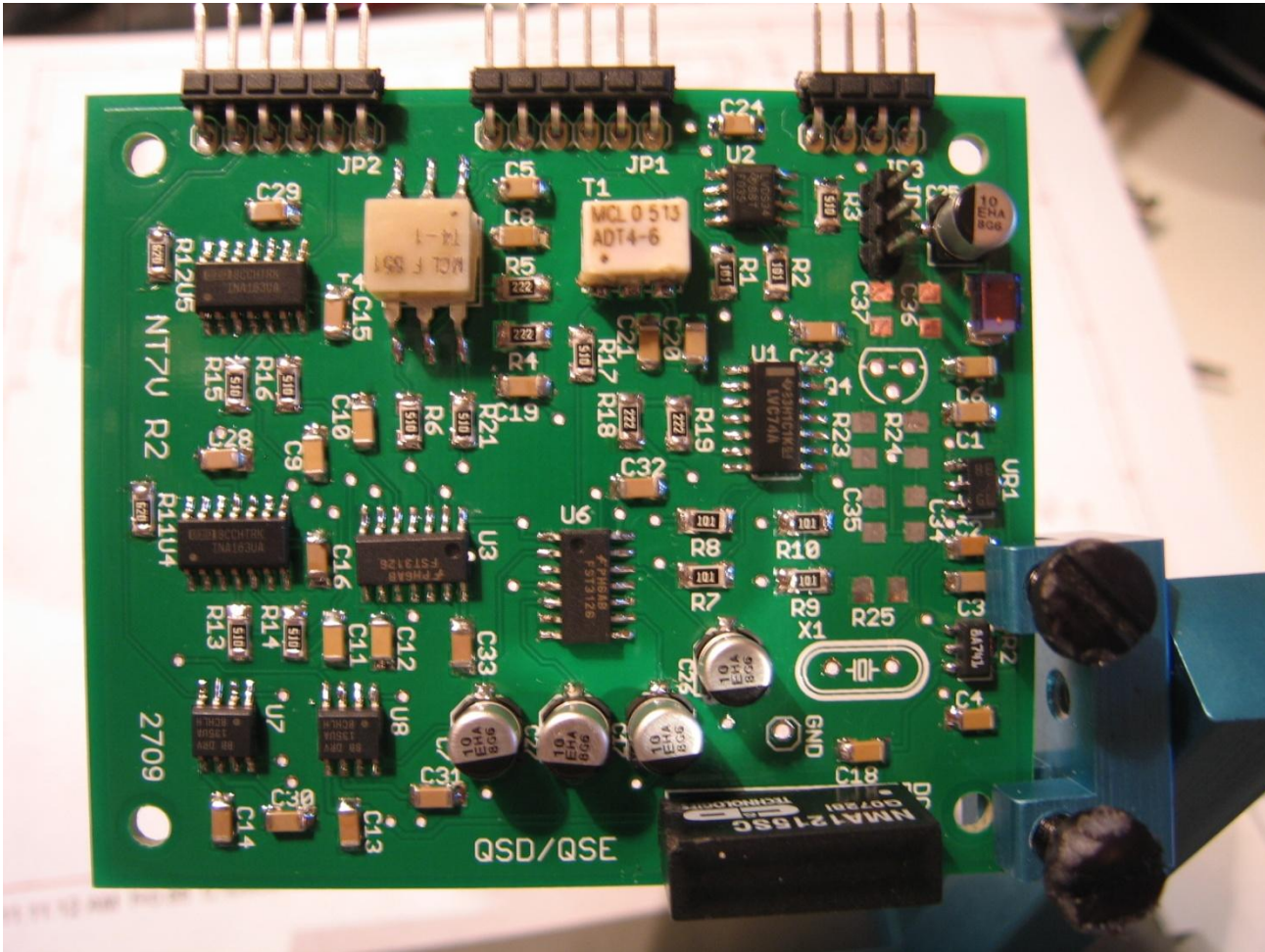

Advertisement – Available on [www.nt7v.com](http://www.nt7v.com)

# Digital SDR

- Third Generation
- Direct conversion but minimal Analog circuits
- Converts directly to digital
- Provides most accurate conversion but –
- Requires Extremely fast and low noise analog to Digital Converter

# Hermes- Digital Transciever

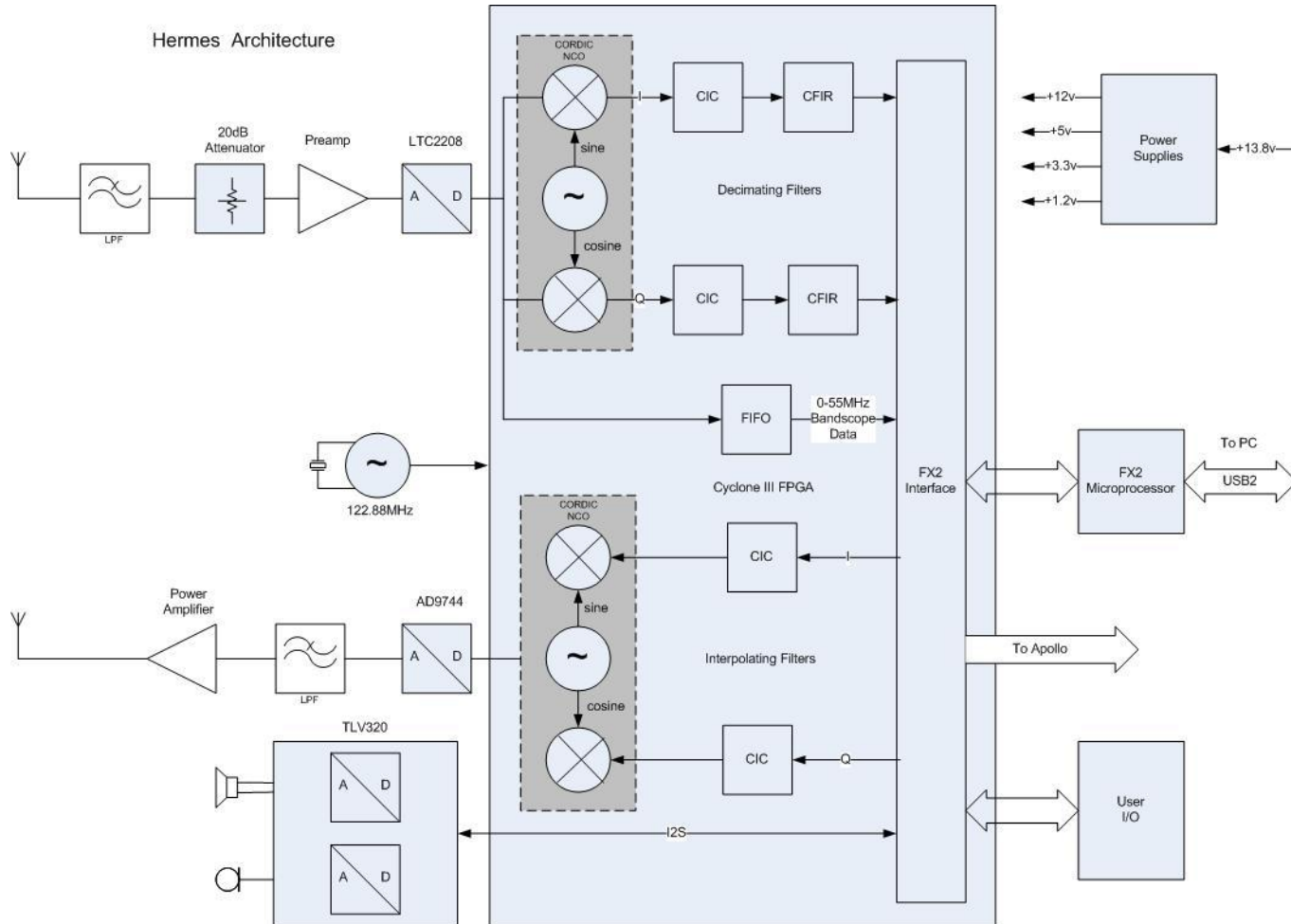

# Hermes – Digital Transceiver

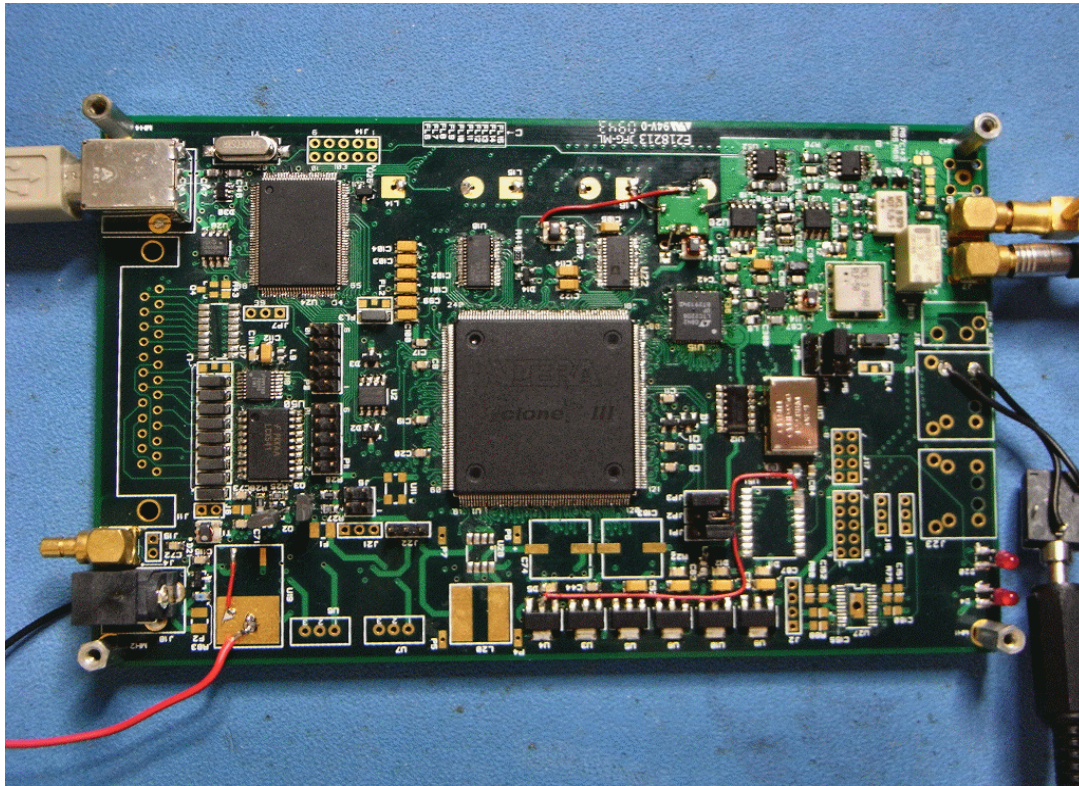

Add Receiver Filters, Power Amp and PC for Complete Transceiver  
More Info at [www.openhpsdr.org](http://www.openhpsdr.org)

# The Future

- All Digital Radio in a box with PC built in
- Performance superior to any analog radio available today
- Expandable via Software
- Cost effective - \$1000-2500